

EurILCA EUROPA CUP 2024

ILCA 4, ILCA 6 & ILCA 7 Classes

6th - 9th July 2024

Warnemünde – Rostock Germany



SAILING INSTRUCTIONS

Version 14 march 2024

CO-ORDINATING AUTHORITY

EurILCA: European Region of ILCA

www.eurilca.org email: entryeurilca@gmail.com

Preamble:

EurILCA reminds us that sporting events are above all a space for exchanges and sharing open and accessible to all. As such, competitors and support persons are asked to behave in all circumstances, on land and on the water, in a courteous and respectful manner regardless of origin, gender or sexual orientation. from other

1. RULES

- 1.1. The regatta will be governed by the *rules* as defined in the Racing Rules of Sailing.
- 1.2. No national authority prescriptions will apply.
- 1.3. The ILCA class rule 7(a) is restricted as follows: Only one person shall be on board whilst racing. The person shall be named on the entry form.
- 1.4. If there is a conflict between languages the English text will take preference.
- 1.5. Races will be started with no less than 5 knots wind
- 1.6. RRS Appendix P, Special for Rule 42, will apply. See SI 15.1

2. NOTICES TO COMPETITORS

- 2.1. Notices to competitors will be posted online notice board at the notice board section at <https://www.manage2sail.com/en-US/event/WarnemuenderWoche2024>
- 2.2. Coach meeting will be held the first day of racing at 1000 hrs at the launching area south.

3. CHANGES IN SAILING INSTRUCTIONS

- 3.1. Any changes to the Sailing Instructions will be posted before 0900 on the day it will take effect.
- 3.2. The scheduled time of the races for each day shall be specified in a notice posted by 2000 on the day before it will take effect.
- 3.3. Any reassignment of events or fleets to course areas will be posted before 0900 hrs. on the day it will take effect, or if flag AP is displayed ashore, 30 minutes before flag AP for that class or fleet is removed.

4. SIGNALS MADE ASHORE

- 4.1. Signals made ashore will be displayed on the signal mast on the Mittelmole Warnemünde at the launching area south.
- 4.2. When flag AP is displayed ashore, '1 minute' is replaced with 'not less than 60 minutes' in the race signal AP. This changes Race Signals AP.
- 4.3. [DP][NP] Flag D displayed with one sound means "The warning signal will be made not less than 60 minutes after flag D is displayed" No boat shall leave her berthing area until this signal is made.
- 4.4. When a signal ashore is displayed over a racing area flag and/or fleet flag(s) it shall apply to that racing area/fleet(s) only.

5. BOATS AND EQUIPMENT

- 5.1. In the event of damage, boats and equipment may only be substituted with the written permission of the technical committee, international jury or race committee.
- 5.2. If the damage occurs later than 90 minutes before the first scheduled start on a racing day and before the start of the last race of the day, provisional verbal permission shall be obtained from the technical committee, international jury or race committee. The written permission of the technical committee, international jury or race committee shall be applied for before the end of Protest Time at the end of the day in which the substitution takes place.

6. FORMAT OF RACING

The ILCA Class is divided in ILCA 7, ILCA 6 and ILCA 4 fleets and each fleet will have separate starts.

7. SCHEDULE OF RACES

- 7.1. The scheduled time for the first warning signal for the first race of the first day is 1200 hrs.
- 7.2. On the last day, no more than 2 races may be scheduled and no warning signal for any fleet will be made after 1400 hrs.

8. CLASS FLAGS

- ILCA 7: Fleet Class flag (white flag with ILCA logo)
- ILCA 6: Fleet Class flag (green flag with ILCA logo)
- ILCA 4: Fleet Class flag (yellow flag with ILCA logo)

9. RACING AREAS

- 9.1. The approximate Racing area will be displayed on the official notice board / Appendix 1
 - ILCA 4 and ILCA 7 fleets will sail on course BRAVO. (ALPHA AREA)
 - ILCA 6 fleets will sail on course DELTA. (BRAVO AREA)
- 9.2. Assignments of fleets to race areas may be changed according SI 3.3.

10. THE COURSES

- 10.1. The SI Addendum A shows the courses, including the approximate angles between legs, the order in which marks are to be passed, and the side on which each mark is to be left.
- 10.2. Before the warning signal for each fleet, the race committee will display course signals.
- 10.3. No later than the warning signal, the race committee signal boat will display the approximate compass bearing of the first leg.
- 10.4. The course may be shortened to finish at any mark provided that 3 or more legs will have been sailed
- 10.5. When one gate mark is missing, the remaining mark shall be rounded to port
- 10.6. Marks will be described in the SI Addendum A.

11. THE START

- 11.1. The starting line will be between two staffs displaying a large orange flag on two race committee vessels
- 11.2. [DP] A buoy may be attached to the race committee starting vessel ground tackle. Boats shall not pass between this buoy and the race committee starting vessel at any time.
- 11.3. [DP] Boats whose warning signal has not been made shall sail at least 50 meters away from and to leeward of the starting line during the starting sequence for other races.
- 11.4. A boat starting later than 4 minutes after her starting signal will be scored DNS without a hearing. This changes rules A.4 and A.5.
- 11.5. To alert boats that a race or sequence of races will begin soon, the orange starting line flag will be displayed with one sound at least five minutes before any other procedure.
- 11.6. Races will be started as follows, according to RRS 26.

| Time before start | Signal | Sound signal |
|-------------------|----------------------------------|--------------|
| 5 minutes | Warning | 1 sound |
| 4 minutes | Preparatory (P, U or Black flag) | 1 sound |
| 1 minute | Last minute | 1 sound |
| 0 minutes | Start | 1 sound |

11.7. Starting under Black Flag Rule Penalty

Rule 30.4 is altered adding the follows: sail numbers will be displayed for at least 3 minutes. A long sound signal will be made when the numbers are initially displayed.

12. CHANGE OF THE NEXT LEG OF THE COURSE

- 12.1.** When it is not possible to change the position of the original marks, the course may be reset using one or more new marks. When new marks are already in use, the course may be reset using original marks.
- 12.2.** Except at a gate, boats shall pass between the race committee boat signalling the change of the next leg and the nearby mark, leaving the mark to port and the race committee vessel to starboard. This changes rule 28.1.

13. THE FINISH

The finishing line will be between a staff displaying a blue flag on a race committee vessel and the finishing mark described in the SI Addendum A.

14. TIME LIMITS AND TARGET TIMES

- 14.1.** The length of the course will be set for a target time of 50 minutes. Failure to meet the target time will not be grounds for redress. This changes rule 62.1(a).
- 14.2.** Boats failing to finish within 20 minutes after the first boat sails the course and finishes will be scored Did Not Finish without a hearing. This changes rules 35, A.4 and A.5.

15. PENALTY SYSTEM

15.1. Appendix P will apply with the following changes:

15.1.1. [SP] If a first penalty is after a boat has crossed the finish line, the penalty will be a 10% Scoring Penalty without a hearing calculated as stated in RRS 44.3(c) but not more than a DSQ.

15.1.2. RRS P4 is replaced with "An action by the jury under RRS P1.2 shall not be grounds for a request for redress by a boat under RRS 60.1(b). The jury may initiate a redress hearing and may give redress for an action under RRS P1.2 by a member of the jury or its designated observer".

15.2. Measurement Penalties

15.2.1. [NP] Measurement protests will only be accepted from technical committee, race committee or jury.

15.2.2. [SP] If a boat is sailed without a centreboard stopper, or with no mast retention line attached (class rule 3(b) xi), a scoring penalty of 30% of the score for did not finish rounded to a whole number (rounding 0.5 upward) will, without a hearing, be added to the boats score in the last completed race in which she was racing without a centreboard stopper or the retention line. However, she shall not be scored worse than DNF. This changes RRS 63.1 and RRS A5.

15.2.3. [SP] If a sail, top mast, or bottom mast has been changed prior to a race without the permission required by SI 5.2 the sailor will be disqualified without a hearing from the last completed race when the change was used. This changes rule 63.1.

15.2.4. [DP] For any other measurement protest, the jury may apply an alternative penalty to disqualification.

15.3. Scoring and arbitration penalties

- 15.3.1. Scoring penalties will be applied according to RRS 44.3(c)
- 15.3.2. The scoring abbreviation for an arbitration penalty is [ARB].
- 15.3.3. A scoring penalty in a split fleet will be based on the number of competitors in the largest group.

16. PROTESTS AND REQUEST FOR REDRESS

- 16.1. The Jury Office is located at the first floor of the “Seglerheim” The official jury notice board is online at <https://www.manage2sail.com/en-US/event/WarnemuenderWoche2023?#!/> section notice board.
- 16.2. Protests shall be delivered at the Race Office or on online system as stated in SI 16.1, within the protest time which will begin as soon as practicable after the finish of the last boat in each fleet. The protest time limit will daily be decided and posted on the official notice board and may be different for each fleet.
Protest hearings will be held in the Jury office.
- 16.3. Notices will be posted on official jury notice board no later than 30 minutes after the protest time limit to inform competitors of hearings in which they are parties or named as witnesses.
- 16.4. Notices of protests by the international jury or race committee or technical committee will be posted on official jury notice board to inform boats under rule 61.1(b).
- 16.5. A list of boats that have been penalized under Appendix P will be posted on the official notice board.
- 16.6. [DP] Breaches of instructions 5.2, 19, 21, 22 and 24 shall not be grounds for a protest by a boat. This changes rule 60.1(a). For these breaches the international jury may apply a penalty less than disqualification.
- 16.7. On the last scheduled day of racing or of the qualifying series, (if applied) RRS 66.2 (a) will apply (30 minutes)
- 16.8. Decisions of the international jury will be final as provided in rule 70.5
- 16.9. [DP] the notation ‘[DP]’ in a rule in the SI means that the penalty for a breach of that rule may, at the discretion of the protest committee, be less than disqualification. (Penalties for breaches of class rules, or rules in the NoR or SIs)
- 16.10. [NP] denotes a rule that shall not be grounds for protests by a boat. This changes RRS 60.1(a)
- 16.11. [SP] denotes a rule for which a standard penalty may be applied by the race committee technical committee without a hearing or a discretionary penalty applied by the international jury with a hearing;
- 16.12. A list of these breaches and the associated standard penalties will be posted on the Official Notice Board. However, the race committee / technical committee may protest a boat when they consider the standard penalty to be inappropriate. This changes RRS 63.1 and Appendix A5.

17. ARBITRATION SYSTEM

Appendix T RRS 2021-24 will apply.

18. [DP] EQUIPMENTS AND MEASUREMENT CHECKS

A boat and equipment may be inspected at any time for compliance with the class rules, as wet clothing rules at the discretion of the technical committee, race committee or international jury.

19. [DP] [NP] SAFETY REGULATIONS

- 19.1. The race committee will protest a boat for a breach of these safety regulations.
- 19.2. Competitors shall wear personal flotation devices at all times when afloat, except briefly while changing or adjusting clothing or personal equipment.
- 19.3. Competitors who require assistance from rescue boats should wave one arm with hand open. If no assistance is required, the arm should be waved with fist closed.
- 19.4. If considered necessary, a competitor may be ordered by a race organisation boat to abandon his or her boat and board a rescue vessel.

-
- 19.5.** A boat that retires from a race shall notify the race committee as soon as possible. The boat shall complete a retirement declaration form at the regatta office on return ashore.
- 19.6.** Flag V, when race committee boats displayed flag V, all team and support boats shall coincide with safety leader of the racing area
- 19.7.** Boats shall avoid commercial traffic and shall cross shipping channels at right angles only.
- 19.8. [SP] Sign-In/-Out:**
- 19.8.1** RFID wristbands are provided at registration.
- 19.8.2** A crew member of each boat shall personally sign-out each day when leaving their berth for racing by presenting their personal RFID wristband to a terminal. After returning ashore a crew member of each boat shall promptly and personally sign-in by again presenting their personal RFID wristband to a terminal.
- 19.8.3** Each boat is responsible for verifying that the terminal acknowledged their sign-out/sign-in and require assistance if needed. The terminal will display one crew's name and the boat's sail number if the sign-out/sign-in was successful.
- 19.8.4** In case of loss the boat is responsible for replacement. If the RFID wristband was lost at sea, the boat shall, after returning ashore, promptly and personally report their return to the race office and request a new RFID wristband. Thereafter, the boat shall immediately sign-in by presenting her new personal RFID wristband to a terminal.
- 19.8.5** Locations of the terminals is at the Race Office Mittelmole.
- 19.9** Safety Regulations
- 19.9.1** Boats not leaving the harbour for a scheduled race, shall promptly notify the race office.
- 19.9.2** A boat that retires from a race shall notify the race committee at the first reasonable opportunity. This boat shall inform personally the race office no later than the protest time limit.
- 19.9.3** In case of a critical weather situation the race committee will give the following signal: three guns with green signal ammunition from a race committee vessel. The signal will be given after all races in the racing area are abandoned. This means:
- for boats: Safety first for all crews. Sail in the safest way to the next harbour.
 - for all support person vessels: Observe and escort boats leaving the racing areas and support the race committee in rescuing competitors and boats.
 - All support person vessels shall monitor VHF channel 16 for search and rescue instructions.
- Telephone number for emergency calls will be published at registration.
- 19.9.4** If the crew is rescued, the abandoned boat shall be marked by the crew or a support person with a red-white-striped hazard tape to signal that the crew is safe. If possible, the tape shall be tied at or near the bow of the boat.

20. SCORING

- 20.1.** When less than 4 races have been completed, a boat's regatta score will be the total of her race scores.
- 20.2.** When 4 or more races have been completed, a boat's regatta score will be the total of her race scores excluding her worst score.

21. [DP] ACCREDITED TEAM AND SUPPORT PERSONS/ VESSELS

- 21.1.** The addendum "Support team regulations" will apply for all team and support boats.
- 21.2.** Support vessel movement
- Except when participating in rescue operations support vessel shall stay outside the racing area during a race, that is from the time of the first warning signal until all boats have finished or the race committee signals a postponement or abandonment of all fleets without the intention to start a next race soon (orange down). In addition, when any boat is racing between mark 5 and the finish support vessels shall remain 100m to windward of the finish line or when coming from mark 4 shall reduce to idle speed when crossing a line directly downwind starting at mark 5 (red zone)."
- It does apply to the 2 types of courses who are used.

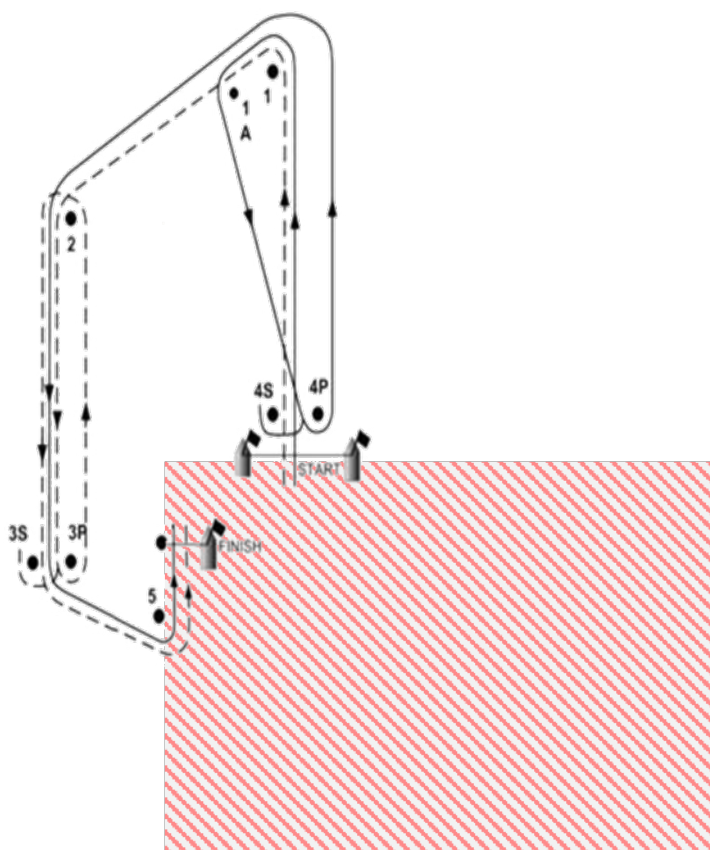

21.3. Accomplishments

If an accredited boat does not comply with this instruction, or its crew has an incorrect behaviour, the accreditation may be suspended, cancelled, and/ or no more issued in next Europa Cup of the series. That decision may be made by the Jury with the EurILCA Representative.

22. INSURANCE

Each participating boat shall be insured with valid third-party liability insurance with a minimum cover per event as stated in the NoR.

23. LIABILITY

The host sailing club, the National Authority and EurILCA, their officers, members and volunteers do not accept liability for loss of life or property, personal injury or damage caused by or arising out of the EurILCA Europa Cup Regattas and competitors take part in the Regattas entirely at their own risk. The establishment of the Notice of Race and the Sailing Instructions in no way limits or reduces the complete and unlimited responsibilities of a competitor being solely and entirely responsible for the management of a boat he or she is sailing. A competitor must be of good health and a competent sailor capable of sailing an ILCA dinghy in strong winds. It is the responsibility of each sailor to decide to participate in a race or to continue racing.

24. RIGHTS TO USE NAME AND LIKENESS

By participating in this event, competitors automatically grant to the organizing authority, the Media services providers and the event sponsors the right, in perpetuity, to make, use, and show, at their discretion, any photography, audio and video recordings, and other reproductions of them made at the venue or on the water from the time of their arrival at the venue, until their final departure, without compensation for the purpose of news reporting, regatta documentary, advertising to promote the regatta, the national or the international class association or sailing, and advertising where the above pictures/video recordings/etc. are shown in the context of sailors/participants competing in Europa Cup Regattas.

Addendum A – EurILCA Europa Cup

1. COMPETITION FORMAT

- 1.1. Where a fleet is bigger than 80 boats, (or close to 80 at discretion of the Race Committee) it can be split into groups.
- 1.2. The organising authority will divide the boats in the split fleet(s) into groups of, as nearly as possible, equal size.
 - 1.2.a. When in a fleet there is a presence of at least 40 girls or ladies' group can be constituted,
 - 1.2.b. Each appropriate Fleet will be split into 2 groups called Yellow and Blue or in 3 groups called Yellow, Blue and Red; or in 4 groups with the green group.
 - 1.2.c. Boats will be possibly reassigned to groups each day after racing based on the overall available results.
 - 1.2.d. The polling will be made with Manage2Sail scoring system, with the alternate option.
- 1.3. The notice of groups will be posted on the official notice board as soon as possible before the first race of the day. The starting signal will be made no earlier than 60 minutes after the time of the posted notice.
- 1.4. If all groups of a split fleet have not completed the same number of races by the end of a day, the groups with fewer races will continue racing the following day until all groups have completed the same number of races.
- 1.5. If at the end of the regatta some groups of a split fleet have more race scores than others, scores for the most recent race(s) will be excluded so that all groups of that fleet have the same number of race scores. That SI will be applied also at the last day to define the groups for finals, see next SI.
- 1.6. When at least 4 races were sailed for all groups, the following days the fleet will be divided in Gold and Silver fleets (and bronze and emerald if in case) and raced in "finals" format. See NoR 7.3. Different final-series groups need not have completed the same number of races.

2. GROUPS IDENTIFICATION

- 2.1. If a fleet is split into groups, the class flag for each group will be the class flag with a coloured flag corresponding to the group colour.
- 2.2. If a fleet is split into groups, each competitor in that fleet will be issued with a sleeve corresponding to the allocated group. The band shall be placed around the lower mast between the gooseneck and boom vang fitting.
- 2.3. In case of finals both flags and coloured bands / flag will be as per gold=yellow; silver=blue; and bronze=red; emerald=green.

3. OFFICIAL BOATS

Official boats will be marked as follows:

| | |
|------------------------------|-----------------------|
| Race Committee | With flag „RC“ |
| Jury | With flag „Jury“ |
| Technical Committee | With flag „M“ |
| Rescue / First Aid / Medical | With flag „Rescue“ |
| Media / Press | With flag „Press“ |
| TV operation | With yellow flag „TV“ |

4. COURSE DIAGRAM

4.1 STANDARD COURSE

This course allows the consecutive starts of fleets.

Course 1 Outer Loop: I.C. Numeral pennant 1 displayed.

Course 2 Inner Loop: I.C. Numeral pennant 2 displayed

That is used when you have up three fleets or 4 fleets of small size.

The diagram shows the course, the order in which marks are to be passed and the side on which each mark is to be left.

The leg between marks 3S/3P and mark 5 may be laid shorter than the leg between mark 1 and mark 2 so that the finish line is not directly to leeward of the start line.

Mark rounding order:

Outer Loop: START, 1, 2, 3S/3P (gate), 2, 3S/3P (gate), 5, FINISH

Inner Loop: START, 1, 1A, 4S/4P (gate), 1, 2, 3S/3P (gate), 5, FINISH

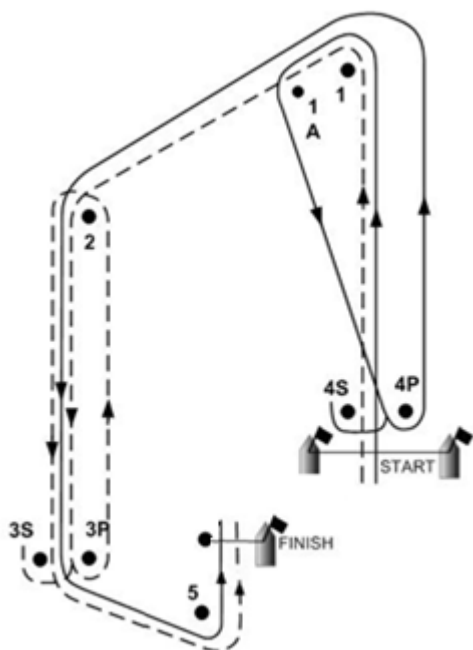

The ILCA 4 are always sent on the inner loop.

4.2 ALTERNATIVE COURSE

This course allows the consecutive starts of fleets.

This is used when you have to sail in narrow waters, like in a river preferably with no more than two fleets. The angle at Mark 1 is 60-70°; the mark angle 2 is 110-120° to left, angle in mark 3 and 4 is 60°.

| Wind from 5 to 9 knots | | Wind stronger than 9 knots |
|------------------------|------------|----------------------------|
| Leg | Leg length | Leg length |
| Start – 1 | 0.8 nm | 1.0 nm |
| 1 – 1A | 0.05 nm | 0.1 nm |
| 1A-2 | 0.6 nm | 0.8 nm |
| 2-1 | 0.6 nm | 0.8 nm |
| 2-3 | 0.4 nm | 0.5 nm |
| 3-4 | 0.4 nm | 0.5 nm |
| 5-finish | 0.2 nm | 0.3 nm |

The distance between the Starting and Finish line is roughly 0.1 nm.

5. [DP] TRASH DISPOSAL

RRS 47 applies. Trash may be placed aboard support and race committee vessels.

6. [DP] ADVERTISING

6.1. Regulation WS 20 will be applied.

6.2. Boats shall display advertising supplied by the organizing authority if applicable. Details shall be specified as follows:

.....

7. PRIZES

7.1. Prizes are stated by the NoR 15.1.

7.2. Prizes will be assigned also if only one race will be sailed. In case of ties the prize will be raffled.

7.3. Additional prizes may be introduced.

8. EVENTUAL FORBIDDEN AREAS

Peculiar obstructions and forbidden areas are described in that Appendix

9. EVENTUAL LOCAL RECOMMENDATIONS

Peculiar local recommendations are described in that Appendix.

10. [DP] RADIO COMMUNICATION

A boat shall neither make radio transmissions while racing nor receive radio communications not available to all boats, except in an emergency or when using equipment provided by the race committee.

Race committees:

Alpha Area (ILCA 4 & ILCA 7): Dr. Jan Prockat (IRO, GER)

Bravo Area (ILCA 6): Christina Buch (IRO, GER)

Jury: Dr. Jörn-Christoph Jansen (IJ, GER)

Chair: Dr. Jörn-Christoph Jansen (IJ, GER)

Technical Inspector: Jonas Renken (NM, GER)

Race Organization: Peter Ramcke (IRO, GER)

Addendum B – EurILCA Europa Cup EurILCA Europa Cup “Racing Areas”

