

02 - 09 October 2021

## **Sailing Instructions**

**Venue: Varna, Bulgaria**

*[NP] denotes a rule that shall not be grounds for protests by a boat. This changes RRS 60.1(a).*

*[SP] denotes a rule for which a standard penalty may be applied by the race committee (RC) without a hearing, or a discretionary penalty applied by the protest committee (PC) with a hearing. This changes RRS 63.1 and A5.*

### **1. RULES**

- 1.1 See NoR 1
- 1.2 RRS Appendix T will apply
- 1.3 Races will not be started with a wind below 5 knots.

### **2. CHANGES IN SAILING INSTRUCTIONS**

- 2.1 Any change to the sailing instructions will be posted before 90 min before the first warning signal on the day it will take effect, except that any change to the schedule of races will be posted before the end of the last protest time or 20:00, whichever is later, on the day before it will take effect.

### **3. COMMUNICATION WITH COMPETITORS**

- 3.1 Notices to competitors will be posted on the online official notice board :  
<https://www.racingrulesofsailing.org/documents/2651/event>  
No printed documents are available
- 3.2 A boat shall neither make radio transmissions while racing nor receive radio communications not available to all boats, except in an emergency.
- 3.3 The race office is located at Varna harbour.  
On racing days the race office is open from 09:00 until 30 minutes after the closing of the protest time limit unless extended at the discretion of the race committee.

### **4. CODE OF CONDUCT**

- 4.1 [NP] Reasonable actions by event officials to implement COVID-19 guidance, protocols, or legislation, even if they later prove to have been unnecessary, are not improper actions or omissions.
- 4.2 [DP] [NP] Competitors and support persons shall handle any equipment and place advertising provided by the organizing authority with care, seamanship, in accordance with any instructions for its use and without interfering with its functionality.

### **5. SIGNALS MADE ASHORE**

- 5.1 Signals made ashore will be displayed on the signal mast near the Race Office.
- 5.2 When flag AP is displayed ashore, "1 minute" is replaced with "not less than 60 minutes" in the race signal AP. This changes Race Signals AP.
- 5.3 [NP] [DP] Flag G displayed with two sounds (one when removed) means "No boat shall go afloat until this signal is removed. The first warning signal will be made not less than 60 minutes after flag G is removed.

### **6. SCHEDULE**

- 6.1 See NoR 8
- 6.2 An extra race may be sailed on any day to enable the full number of scheduled races to be completed.
- 6.3 On the first scheduled racing day a support person / skippers meeting will be held 150 min before the first warning signal of the day at Varna Harbor.
- 6.4 A daily support person / skippers meeting may be held 150 min before the first warning signal of the day at Varna harbour.

### **7. ASSIGNMENTS TO FLEETS, OPENING, QUALIFYING, FINAL SERIES**

- 7.1 The event consists of a single opening series and each class will have separate starts.
- 7.2 If one class is bigger than 80 boats (or close to 80), it can be split into fleets at the discretion of the Race Committee, see Addendum A.

# EurILCA Senior European Championships & Open European Trophy 2021

## 8. RACING AREAS

8.1 The Racing area will be displayed on the official notice board / Addendum C

## 9. CLASS FLAGS

9.1 Fleet flags for ILCA 7, ILCA 6 men and ILCA 6 women are described in Addendum C.

## 10. THE COURSES

- 10.1 The SI Addendum B shows the courses, including the approximate angles between legs, the order in which marks are to be passed, and the side on which each mark is to be left.
- 10.2 Before the warning signal for each fleet, the race committee will display course signals.
- 10.3 No later than the warning signal, the race committee signal vessel will display the approximate compass bearing of the first leg.
- 10.4 The course may be shortened to finish at a rounding mark or a gate provided that 4 or more legs have been sailed on an outer course and at least 3 or more legs have been completed on an inner course (excluding the leg between mark 1 and mark 1A).

## 11. MARKS

11.1 Marks will be described in the SI Addendum C.

## 12. OBSTRUCTIONS

12.1 Obstructions and forbidden areas are described in that Addendum C

## 13. THE START

- 13.1 The starting line will be between two staffs displaying a large orange flag on two race committee vessels
- 13.2 A boat starting later than 4 minutes after her starting signal will be scored DNS without a hearing. This changes RRS A5.1 and A5.2.
- 13.3 [DP] When a starting sequence is in progress, boats whose warning signal has not been made shall avoid the starting area.  
The starting area is defined as the area 100 meters from the starting line and marks in all directions.
- 13.4 To alert boats that a race or sequence of races will begin soon, the orange starting line flag will be displayed with one sound at least five minutes before any other procedure.
- 13.5 The warning signal for the subsequent starts will be made as soon as practicable after the previous start.
- 13.6 RRS 30.4 is changed by adding: sail numbers will be displayed for at least 3 minutes before a new starting sequence of her class / fleet. A long sound signal will be made when the numbers are initially displayed.  
A boat whose number is so displayed shall leave the racing area, before her new preparatory signal. If she fails to do so, she is liable to be scored DNE.

## 14. CHANGE OF THE NEXT LEG OF THE COURSE

- 14.1 To change the next leg of the course, the race committee will
- (a) will lay a new mark, or move the mark or
  - (b) move the finishing line, or
  - (c) move the leeward gate.
- When a new mark is laid, the original mark will be removed as soon as possible.  
If there is an offset mark, the offset mark is to be ignored.  
When in a subsequent change a new mark is replaced, it will be replaced by an original mark.
- 14.2 Except at a gate, boats shall pass between the race committee boat signalling the change of the next leg and the nearby mark, leaving the mark to port and the race committee vessel to starboard. This changes RRS 28.1.

## 15. THE FINISH

15.1 The finishing line will be between staffs displaying a blue flag on a signal vessel and on the finishing mark described in the Addendum C.

## 16. PENALTY SYSTEM

- 16.1 RRS Appendix P will apply with the following changes:
- 16.1.1. RRS Appendix P applies as changed by SI 16.1.2 and 16.1.3
  - 16.1.2. RRS Appendix P 2.4 is changed as follows
    - a. If a boat is penalized under rule P2.1 and it was not reasonably possible for her to take the penalty before finishing, she may either take the penalty turns and pass again the finishing line, or accept a scoring penalty of 10% (rounding 0.5 upward) without a hearing.
    - b. If a boat is penalized under rule P2.2 or P2.3 and it was not reasonably possible for her to retire before finishing, she shall be scored as if she had retired promptly.

# EurILCA Senior European Championships & Open European Trophy 2021

16.1.3 For the purpose of Appendix P, in case there are split fleets, races are named Q1 to Qn for the Qualifying series and F1 to Fn for the Final series.

## Summary of Appendix P

Yellow Flag	Immediate penalty or action by boat	After a general recall or a postponement or an abandonment	No action by boat	After a general recall or a postponement or an abandonment
1 <sup>st</sup>	Two turns or 10% (SI 17.1.1)	Can restart	DSQ	Shall not restart if notified of the DSQ.
2 <sup>nd</sup>	Retire (RET)	Shall not restart	DNE	Shall not restart
3 <sup>rd</sup>	Retire (DNE)	Shall not restart	DNE Event	Shall not restart

## 16.2 Measurement penalties

16.2.1. [NP] Measurement protests will only be accepted from technical committee, race committee or jury.

16.2.2. [NP] [SP] If a boat is sailed without a centreboard stopper, or with no mast retention line attached (class rule 3(b) xi), will receive a scoring penalty of 30% of the score for did not finish rounded (0.5 upward) to a whole number, without a hearing, be added to the boat's score in the last completed race in which she was racing without a centreboard stopper or the retention line. However, she shall not be scored worse than DSQ. This changes RRS 63.1.

16.2.3. [NP] If a sail, top mast, or bottom mast has been changed prior to a race without the permission required by SI 20 the sailor will be disqualified without a hearing from the last completed race when the change was used. This changes RRS 63.1.

16.2.4. [NP] [DP] For any other measurement protest, the jury may apply an alternative penalty to disqualification.

## 16.3 Scoring and arbitration penalties will apply according to RRS 44.3c

16.3.1. The scoring abbreviation for an arbitration penalty is [SCP]

16.3.2. A scoring penalty in a split fleet will be based on the number of competitors in the largest group of the class / fleet.

## 16.4 Whistle system

16.4.1. In order to encourage boats to take penalties afloat, jury members may blow a whistle when they see what they believe to be a breach of a rule. If no boat takes a penalty, the international jury may lodge a protest.

## 17. TIME LIMITS AND TARGET TIMES

17.1 The length of the course will be set for a target time of 50 minutes.

17.2 Failure to meet the target time will not be grounds for redress. This changes RRS 62.1(a).

17.3 Boats failing to finish within 20 minutes after the first boat sails the course and finishes will be scored Did Not Finish (DNF) without a hearing. This changes RRS 35, A5.1 and A5.2.

## 18. HEARING REQUESTS

18.1 The Jury Office is located at Varna harbor( look at the map on the event website: <http://brizvarna.org/senior-european-championships-and-open-european-trophy-2021/> )

18.2 Hearing request forms are available on. <https://www.racingrulesofsailing.org/documents/2651/event>

18.3 To request to correct an alleged error in posted race or series results, a boat shall complete a scoring enquiry form on <https://www.racingrulesofsailing.org/documents/2651/event>

18.4 For each fleet, the protest time limit is will be set by the jury.

The protest time limit is 30 minutes after the committee signals no more racing today ashore.

The same time limit applies for requests for redress. This changes RRS 62.2.

18.5 The protest time limit will be posted on the official notice board and may be different for each fleet

18.6 Notices will be posted on official jury notice board no later than 30 minutes after the protest time limit to inform competitors of hearings in which they are parties or named as witnesses.

Hearings may be scheduled to begin before the end of the protest time limit

Hearings will be held in the hearing room, beginning at the time posted.

18.7 A list of boats that have been penalized under RRS Appendix P will be posted on <https://www.racingrulesofsailing.org/documents/2651/event> .

18.8 RRS 66.2(a) is changed to:

"However, on the last day of the qualifying or opening series or on the last scheduled day of racing the request shall be delivered

(1) within the protest time limit if the requesting party was informed of the decision on the previous day;

(2) no later than 30 minutes after the party was informed of the decision on that day."

18.9 Decisions of the international jury will be final as provided in RRS 70.5.

# EurILCA Senior European Championships & Open European Trophy 2021

## 19. SAFETY REGULATIONS

- 19.1 RRS 40.1 applies at any time when boats are afloat.
- 19.2 [DP] [NP] Competitors who require assistance from rescue vessels should wave one arm with hand open. If no assistance is required, the arm should be waved with fist closed.
- 19.3 [DP] [NP] If considered necessary, a competitor may be ordered by a race organisation vessel to abandon his or her boat and board a rescue vessel.
- 19.4 If a boat is abandoned, it will be marked with a hazard tape tied through the bow eye to signal that the sailor is safe
- 19.5 [DP] [NP] A boat that retires from a race shall notify the race committee as soon as possible. Ashore, the boat shall submit a retirement declaration form at the regatta office.
- 19.6 [DP] [NP] Boats shall avoid commercial traffic and shall cross shipping channels at right angles only.

## 20. EQUIPMENT SUBSTITUTION

- 20.1 In the event of damage, boats and equipment may only be substituted with the electronic written permission of the technical committee by filling a request on <https://www.racingrulesofsailing.org/documents/2651/event>.
- 20.2 If, on a racing day, the damage occurs later than 90 min before the first warning signal of the day and before the last warning signal of the last race of the day, provisional verbal permission shall be obtained from the technical committee. The written permission of the technical committee shall be applied for before the end of protest time limit at the end of the day in which the substitution takes place.

## 21. EQUIPMENTS AND MEASUREMENT CHECKS

- 21.1 [DP] A boat and equipment may be inspected at any time for compliance with the class rules, as wet clothing rules at the discretion of the technical committee.
- 21.2 Competitors may wear a heart rate monitor which shall not be capable of displaying, delivering, transmitting, receiving, calculating, correlating or storing information about wind speed, wind direction, boat speed or boat position.

## 22. SCORING

- 22.1 See NoR 19

## 23. OFFICIAL VESSELS

- 23.1 Official vessels will be marked as follows:

Race Committee	With flag "RC"
Jury	With flag "J" or "Jury"
Technical Committee	With flag "M"
Rescue / First Aid / Medical	With flag "Rescue"
Media / Press	With flag "Press" or "MEDIA"
TV operation	With yellow flag "TV"

- 23.2 [NP] Failure of a committee vessel to fly an identifying flag will not be grounds for redress under RRS 60.1(b).

## 24. SUPPORT TEAMS

- 24.1 Except when participating in rescue operations, support person vessels shall not be:
- *closer than 100m to any boat racing;*
  - *within 100m to leeward of the starting line or within 100m of its marks from the time of the preparatory signal until all boats have left the starting area. However, when the race committee signals a postponement or abandonment, support person vessels may enter the area to leeward of the starting line and its extensions to service their athletes but shall restrict their speed to 5 knots;*
  - *between any boat racing and the next mark of the course;*
  - *between the inner and outer trapezoid courses when boats are racing on both courses;*
  - *within 100m of any mark of the course while boats are in the vicinity of that mark;*
  - *within 100m of the finishing line and its marks while boats are finishing;*

# EurILCA Senior European Championships & Open European Trophy 2021

- forbidden area for support persons vessels while boats are racing

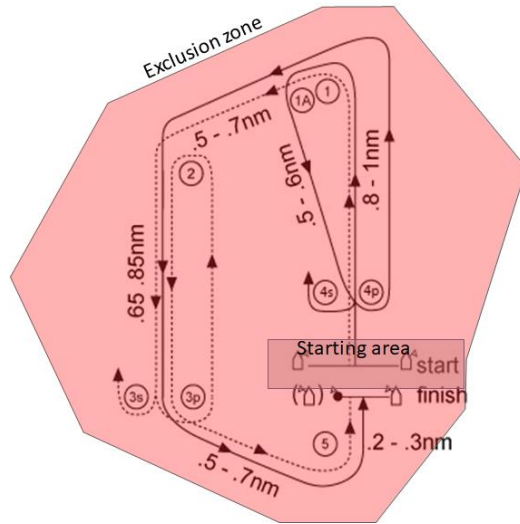

In addition when any boat is racing between mark 5 and the finish, support vessels shall remain 100m to windward of the finish line or when coming from mark 4 shall reduce speed below 3 knots when crossing a line directly downwind starting at mark 5 (red zone).”

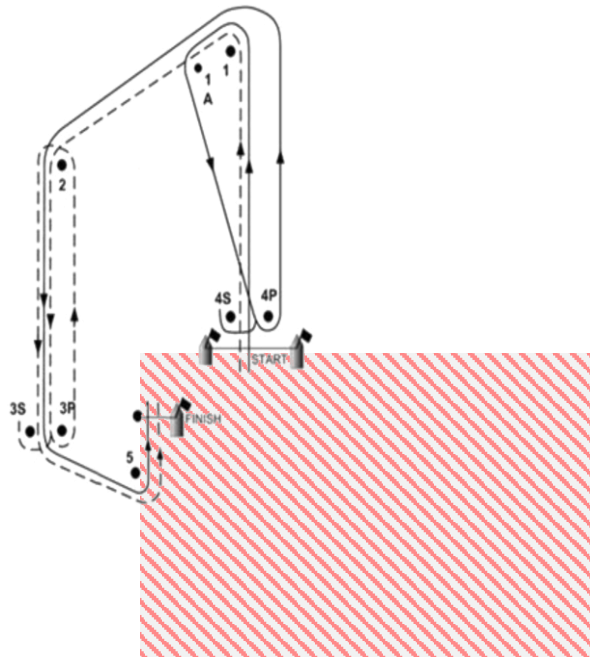

- 24.2 Support person vessels should proceed around the racing area in such a way to minimise the effect their wash will have on boats racing. Vessels that are motoring above five knots shall remain at least 150m from any boat racing.
- 24.3 Support person vessels shall clearly display an identification number supplied at registration by the OA. (Reminder: a fee of EUR 100 is required for the registration of support person vessels, identification number and use of the facilities of the harbour plus access to social activities).
- 24.4 Support teams, including all support persons and support person vessels, shall comply with the regulations if any is stated by the organizer.
- 24.5 Each support vessel shall carry at least three hazard warning tapes for the purposes of SI 19.4. The tape is available from the race office.
- 24.6 Each support vessel is required to carry a VHF radio capable of transmitting and receiving all international ship-to-ship channels.
- 24.7 VHF Channel 73 will be used as communication channel between Race Committee and support persons vessels on the water. VHF channel will be given at the initial support persons meeting.
- 24.8 Support vessel drivers and crews shall comply with RRS 40.1 at any time while afloat.

# EurILCA Senior European Championships & Open European Trophy 2021

- 24.9 When the support vessel engine is running support vessel drivers shall be connected to a device that will stop the engine if the boat driver falls out the boat or is otherwise not in control of the boat.
- 24.10 When not in use, support vessels shall be appropriately berthed at the sailing venue in the allocated areas for support vessels for the entire time that these regulations apply.
- 24.11 Support vessels shall comply with local harbour and marina regulations, including speed limits.
- 24.12 If a support vessel does not comply with instructions of SI 19 a discretionary penalty may be applied by the jury to some or all associated competitors and may include restrictions on the movement of the support vessel. This changes RRS 63.9 and 64.5

## 25. EVENTUAL LOCAL RECOMMENDATIONS

- 25.1 If any, specific local recommendations are described in Addendum D.

## 26. TRASH DISPOSAL

- 26.1 Trash may be placed aboard official or support persons vessels or ashore in trash containers.

## 27. TITLES & PRIZES

- 27.1 See NoR 20

---

Race Committee officer: Todor Ivanov  
Jury Chair: Pauline Wilmink  
Technical Inspector: Abadie Charlotte  
Race Organization: Rosen Marangozov  
EurILCA Representative: Zlatko Jakelic  
Results: Miranda Jakelic

# EurILCA Senior European Championships & Open European Trophy 2021

## Addendum A – Qualifying and Final Series

This addendum applies when boats are divided into fleets to sail a qualifying series and a final series.

### A 1 QUALIFYING SERIES

- A 1.1 For the qualifying series boats will be assigned to fleets of, as near as possible, equal size and ability.
- A 1.2 Initial assignments will be made by a seeding committee appointed by the organizing authority and will be posted by 20:00 on the last day of registration.
- A 1.3 Where a practice race is scheduled, the organizing authority may post a practice race fleet assignment one hour before the warning signal on the day of the practice race.
- A 1.4 In the qualifying series boats will be reassigned to fleets after each day of racing, except if on the first day if only one race is completed. If all fleets have completed the same number of races, boats will be reassigned on the basis of their ranks in the series. If all fleets have not completed the same number of races the series scores for reassignment will be calculated for those races, numbered in order of completion, completed by all fleets.
- A 1.5 Reassignments will be made as follows:

	Two fleet format	Three fleets format	Four fleets format
Rank in Series	Fleet Assignment	Fleet Assignment	Fleet Assignment
1 <sup>st</sup>	1	1	1
2 <sup>nd</sup>	2	2	2
3 <sup>rd</sup>	2	3	3
4 <sup>th</sup>	1	3	4
5 <sup>th</sup>	1	2	4
6 <sup>th</sup>	2	1	3
7 <sup>th</sup>	2	1	2
8 <sup>th</sup>	1	2	1
9 <sup>th</sup>	1	3	1
And so on			

- A 1.6 Reassignments will be based on the ranking available at 21:00 that day regardless of protests or requests for redress not yet decided.
- A 1.7 If all fleets have not completed the same number of races by the end of a day, the fleets with fewer races will continue racing the following day until all fleets have completed the same number of races. All boats will thereafter race in the new fleets.
- A 1.8 If four races have not been completed on the last scheduled day of the qualifying series, the qualifying series will continue until the end of the racing day in which a fourth qualifying race is completed.
- A 1.9 If at the end of the qualifying series some qualifying series fleets have more race scores than others, any extra races will be abandoned so that all boats in the qualifying series have the same number of race scores.

### A 2 FINAL SERIES

- A 2.1 Boats will be assigned to final series fleets on the basis of their ranks in the qualifying series.
- A 2.2 There will be the same number of fleets in the final series as there were in the qualifying series.
- A 2.3 The final series fleets will be, as nearly as possible, of equal size but so that the Silver fleet is not larger than the Gold fleet and the Bronze fleet (where it exists) is not larger than the Silver fleet and the Emerald fleet (where it exists) is not larger than the Bronze fleet. Boats with the best qualifying series ranks will race all final series races in the Gold fleet; boats with the next best qualifying series ranks will race in the Silver fleet; boats with the next best qualifying series ranks will race in the Bronze fleet (where it exists); and boats with the next best qualifying series ranks will race in the Emerald fleet (where it exists).
- A 2.4 Any recalculation of qualifying series ranking after boats have been assigned to final series fleets will not affect the assignments except according to RRS 90.3(c) before the first final race or that a redress decision may promote a boat to a higher fleet. Different final series fleets need not have completed the same number of final races.
- The boats in the Gold fleet will be ranked highest, except for a boat penalized in a final series race under RRS 6 or 69

### A 3 FLEET IDENTIFICATION

- A 3.1 ILCA 6 men will sail in a single fleet.  
ILCA 6 women will sail in a single fleet.
- If a class is split into fleets, the class flag for each fleet will be a coloured flag corresponding to the fleet colour.

# EurILCA Senior European Championships & Open European Trophy 2021

A 3.2 While racing each boat shall display a coloured sleeve corresponding to the fleet to which she has been assigned **except for ILCA 6 mens who will not use a sleeve**. The sleeve shall be placed on the bottom mast between the boom vang fitting and the boom.



## Addendum B – Courses

### B 1 COURSES

**Outer Loop:** Start – 1 – 2 – 3s/3p – 2 -3p – 5 – Finish

**Inner Loop:** Start – 1 – 1A – 4s/4p – 1 – 2 -3p – 5 – Finish

*All indicated distances between marks are recommended: the shorter up to 9 kts wind speed; the longest over 9 kts and have to be balanced considering of the current and all other sea conditions to reach the time target of 50 minutes.*

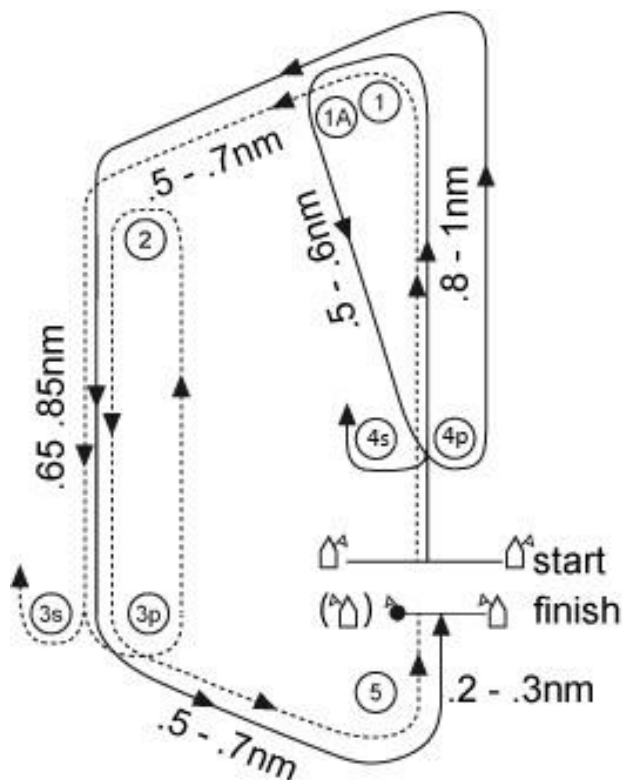

## Addendum C – Racing areas

### C 1 ALPHA AREA

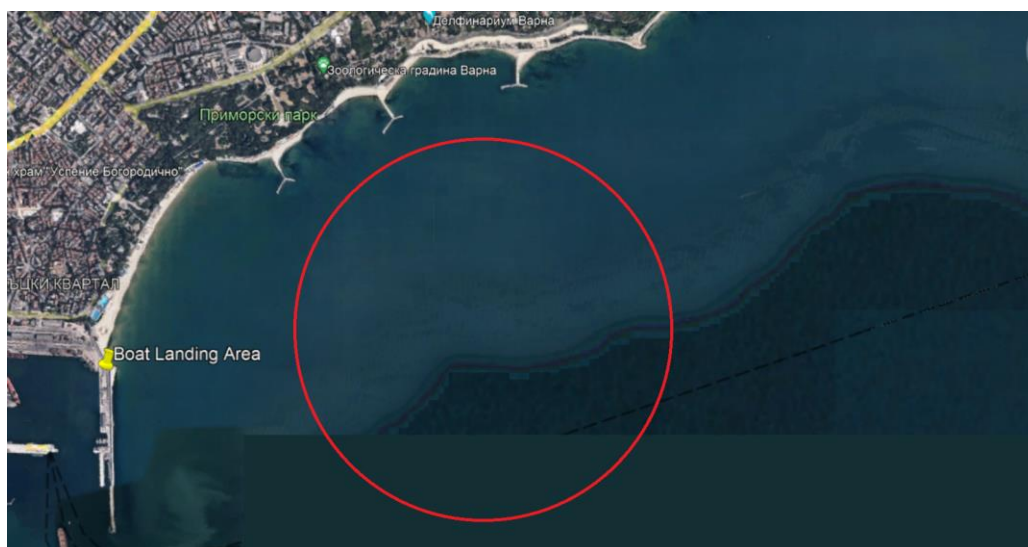

#### C 1.1 MARKS ON ALPHA RACING AREA

Marks	Description
Starting mark	Race committee vessels displaying an orange flag
Mark 1	cylindrical red buoy
Mark 1a	cylindrical red buoy
Mark 2	cylindrical red buoy
Mark 3	cylindrical red buoy
Mark 4	cylindrical red buoy
Mark 5	cylindrical red buoy
Finishing mark	cylindrical red buoy displaying a blue flag
New mark	cylindrical yellow buoy

#### C 1.2 FLEETS ON ALPHA RACING AREA

Fleets	Fleet Flags	Start Sequence	Course
ILCA 6 Women - Green	ILCA flag Green	1 <sup>st</sup> Start	Outer
ILCA 7 Men -Yellow / Gold	Yellow	2 <sup>nd</sup> Start	Outer
ILCA 7 Men – Blue / Silver	Blue	3 <sup>rd</sup> Start	Inner
ILCA 6 Men	Red	4 <sup>th</sup> Start	Inner